

OPERATOR'S MANUAL

613100-1

613104

INCLUDING: OPERATION, INSTALLATION & MAINTENANCE

ALSO INCLUDE MANUALS: 6544X-X AIR MOTOR (97999-64), 641523 CONTROL HANDLE (97999-230), S-633 GENERAL INFORMATION MANUAL (PN 97999-625)

RELEASED: 4-10-67
 REVISED: 8-26-10
 (REV. N)

4-1/4" AIR MOTOR
10:1 RATIO
4" STROKE

613100 -1
WASH PUMP

613104
DETERGENT PUMP ASSEMBLY



READ THIS MANUAL CAREFULLY BEFORE INSTALLING, OPERATING OR SERVICING THIS EQUIPMENT.

It is the responsibility of the employer to place this information in the hands of the operator. Keep for future reference.

SERVICE KITS

- Use only genuine ARO® replacement parts to assure compatible pressure rating and longest service life.
- 637001 for repair of 61371-1 Lower Pump end.
- 61268 for repair of 65444-B Air Motor section.
- 637033 for repair of 641523 Control Handle.

SPECIFICATIONS

Model	613100-1
Type	Air Operated, Wash Pump
Ratio	10:1
Air Motor Diameter	4-1/4" (10.795 cm)
Stroke (Double Acting)	4" (10.16 cm)
Air Inlet	1/2 - 14 NPTF - 1 (f)
Air Exhaust	1-1/4 - 11-1/2 NPTF - 1 (f)
Material Outlet	3/8 - 18 NPTF - 1 (f)
Material Inlet	Barbed
Pump Construction	Series 425 Stainless Steel
Dimensional Data	See Figure 1

PERFORMANCE

Air Inlet Pressure Range	0 - 150 p.s.i. (0 - 10.3 bar)
Fluid Pressure Range	0 - 1500 p.s.i. (0 - 103 bar)
Displacement In³ Per Cycle	11.0 (.18 L)
Cycles Per Gallon	21 (5.5 L)
Maximum Delivery / Min.	3.9 Gallons (14.8 L)
Accessories Available:	61113 Wall Mount Bracket

GENERAL DESCRIPTION

The Aro model 613100-1 and 613104 wash pump has been designed for heavy duty cleaning with detergents, caustics, and dilute acid type cleaners. (The model 613100-1 basic pumps come without accessories).

The 10:1 ratio double acting pump section is separated from the air motor to prevent any cleaning solution from coming in contact with and damaging the air motor.

All metal parts in the pumping section are manufactured from 316 stainless steel or "K" monel, the packing and "O" rings are manufactured from Nitrile, and the packing back-ups and portions of the material piston are manufactured from acetal resins.

Packings, "O" rings, and material pistons of virgin PTFE and packing back-ups of glass filled PTFE are available on special request.

The 4-1/4 inch air motor is of the double acting reciprocating type. The valving in the air motor uses "D" type valves and is mechanical with a pneumatic assist.

The 613104 wash pump may be directly mounted in the two inch bung of a standard 55 gal. drum or, when using the 61113 mounting bracket, the pump can be mounted on the wall or in a 55 gal. open head drum. (The 61139 suction tube comes with a 100 mesh screen).

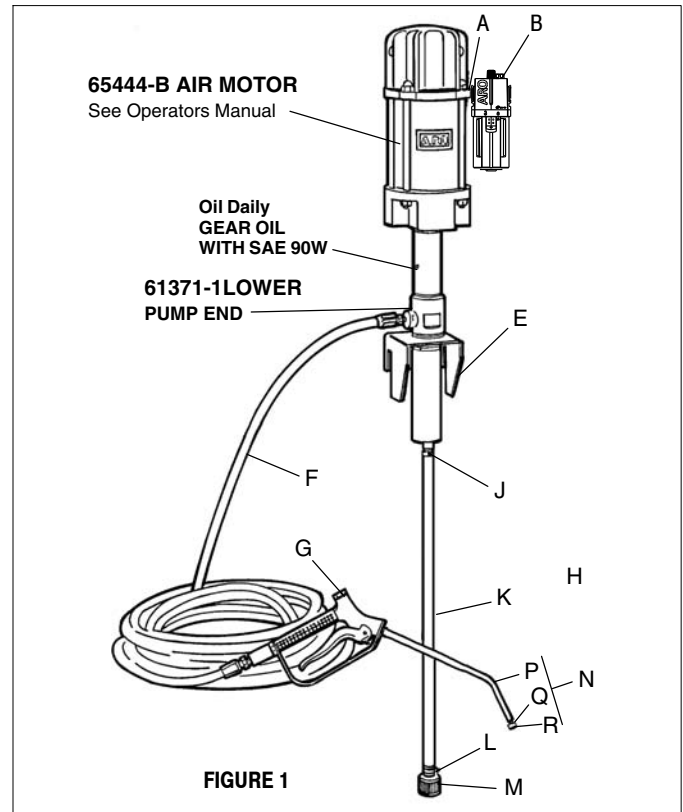

ITEM	DESCRIPTION	PART NO.
A	Nipple	Y27-4-N
B	Airline Lubricator	L36341-110
E	Pump Bracket Assembly (2" Bung)	61113
F	Hose Assembly (3/8 I.D. 2 Fabric)	622427-40
G	Control Handle Assembly	641523
H	Suction Tube Assembly (Includes J, K, L & M)	61139-1
J	Hose Clamp	61204-1
K	Tube	92249-26
L	Hose Clamp	76315
M	Screen Assembly	61138
N	Bent Pipe Assembly (Includes P, Q & R)	61133
P	Bent Pipe	76821
Q	Nozzle Cover	76330
R	Spray Tip	TP6250-18

INGERSOLLRAND COMPANY

209 NORTH MAIN STREET - BRYAN, OHIO 43506

☎ (800) 495-0276 • FAX (800) 892-6276 ©2010

www.ingersollrandproducts.com

CCN 99711491

ARO

IR Ingersoll Rand
 Industrial Technologies

OPERATING PRECAUTIONS

⚠️WARNING **HAZARDOUS PRESSURE.** Do not exceed maximum operating pressure of 1500 p.s.i. (103 bar) at 150 p.s.i. (10.3 bar) inlet air pressure.

**PUMP RATIO X
INLET PRESSURE TO PUMP MOTOR = MAXIMUM PUMP
FLUID PRESSURE**

Pump ratio is an expression of the relationship between the pump motor area and the lower pump end area. EXAMPLE: When 150 p.s.i. (10.3 bar) inlet pressure is supplied to the motor of a 10:1 ratio pump it will develop a maximum of 1500 p.s.i. (103 bar) fluid pressure (at no flow) - as the fluid control is opened, the flow rate will increase as the motor cycle rate increases to keep up with the demand.

⚠️WARNING Refer to general information sheet for additional safety precautions and important information.

OPERATING INSTRUCTIONS

1. Fill air line lubricator bowl with SAE 90 gear oil.
2. Oil the lower pump assembly section by squirting SAE 90 Gear Oil into the two holes marked "Oil Daily".
3. Fill the cleaning solution container with clear water.
4. Connect the air supply line to the air line lubricator.
5. Open the (G) control handle assembly by squeezing the trigger until water sprays out the spray tip.
6. Adjust air line oiler to approximately 1 drop every 2 minutes by turning adjusting screw clockwise for less flow.
7. Close control handle.
8. Add the proper amount of cleaning solution to cleaning solution container. Insert the (N) bent pipe assembly into the cleaning solution and open the control handle assembly. Continue holding the control handle open until spray from the (N) bent pipe assembly has thoroughly mixed the cleaning solution.

NOTE:

- Most cleaning solutions will perform more efficiently in warm water.
 - Powdered detergents will be easier to mix if they are dissolved in a container of hot water first.
 - Consult chemical manufacturer's recommendations for proper mixing and concentration
9. The air supply line should be disconnected when the wash pump assembly is not in operation.

CAUTION: DO NOT ALLOW THE AIR MOTOR TO RUN AFTER THE SOLUTION CONTAINER IS EMPTIED.

CLEANING INSTRUCTIONS

Use the cleaning instructions supplied by the cleaning chemical supplier. General cleaning instructions for detergents and caustics: (In the event cleaning instructions are not supplied by chemical supplier).

1. Lightly and rapidly cleaning solution to object being cleaned.
2. Let cleaning solution stand on the object for two or three minutes.
3. Starting from the bottom up, clean the object with cleaning solution holding the spray tip 6 to 8 inches away from object and at approximately 45°. The 45° angle will produce a chiseling effect for better cleaning.

4. Rinse the object thoroughly with clean water from the top down.

General cleaning instructions for aluminum brightening: (If not supplied by chemical supplier).

1. Apply aluminum brightener to an area of approximately 100 square feet (approximately 3 semi-trailer panels) from the bottom up.
2. Let the brightening solution soak until light foaming occurs on the aluminum.
3. Rinse thoroughly with clear clean water from the top down.

CAUTION: Brightening solution will etch glass and will burn aluminum if permitted to soak after the light foaming occurs.

PUMP PERFORMANCE CHART

Operating Air Pressure (PSIG)	Spray Tip Orifice	Pump Back Pressure (PSIG)	Air Usage (CFM)	Pump Speed (CPM)	Flow Rate (GPM)
50	.042	410	5.66	20	.94
	.052	370	6.62	24	1.16
	.062	330	10.35	35	1.72
75	.042	640	8.75	23	1.09
	.052	600	12.96	32	1.53
	.062	500	19.85	47	2.25
100	.042	880	13.34	27	1.25
	.052	800	19.78	37	1.81
	.062	720	28.80	56	2.68
125	.042	1080	20.00	31	1.44
	.052	1000	26.50	42	2.00
	.062	920	40.00	63	3.00
150	.042	1300	25.50	34	1.59
	.052	1200	34.32	47	2.19
	.062	1100	50.60	68	3.25

PSIG = Pound per square inch gage

CPM = Cycles per minute

CFM = Cubic Feet per minute

GPM = Gallons per minute

NOTE: Pump should not be operated continuously at speeds in excess of 60 cycles per minute.

MAINTENANCE

The basic pump consists of two major components: 1. Air Motor, 2. Lower Pump End. The air motor is connected to the lower pump end by a spacer tube - this allows access for lubricating the upper packing gland in the lower pump end, and to prevent air motor contamination because of normal wear and eventual leakage through material packing gland. The air motor is removable and is to be serviced separately. Refer to air motor manual for service and parts.

- Periodically flush entire pump system with a solvent that is compatible with the material being pump.
- Periodically inspect and replace if necessary the (M) screen assembly on the bottom of the (H) suction tube assembly.
- Refer to Disassembly Procedures of air motor and lower pump end (see Page 3 and 4) for correct breakdown.
- Disassembly should be done on a clean work bench with clean cloths to keep parts clean.
- If replacement parts are necessary, consult drawing containing parts for identification.
- Before assembling, lubricate parts where required. When assembling "O" rings or parts adjacent to "O" rings, care must be exercised to prevent damage to "O" rings and "O" ring groove surfaces.

Daily Maintenance

1. The airline lubricator should be filled with SAE 90 weight gear oil.
2. Maintain the oil level on the packings in the lower pump assembly. Use SAE 90 weight gear oil.
3. The air line should be disconnected from the air motor if the pump sits idle for long periods.

INSTALLATION

(See Figure 1)

1. Attach the (E) pump bracket assembly to the lip of the drum and tighten the retaining screw or bolt the pump bracket assembly to the wall using the 3 holes provided in the back of the (E) pump bracket assembly.
2. Attach the (H) suction tube assembly to the barbs on the bottom of the pump assembly and tighten the (J) hose clamp.
NOTE: Soak (K) tube in hot water for ease of installation over barbs.
3. Place the (H) suction tube assembly and the lower pump assembly through the 2" NPT bung in the pump mounting bracket. Thread the lower pump assembly into the pump mounting bracket, align the material outlet in the direction the (F) material hose should go, and tighten the (8) lower lock nut. (See Figure 4). Loosen (1) upper lock nut,

- (Figure 4), and turn the air inlet of the 65444-B air motor in the direction desired and retighten the (1) upper lock nut.
4. Attach the (A) nipple and (B) airline lubricator.
5. Attach the (F) hose assembly to the 3/8 NPT thread in the material outlet of the pump.
6. Attach the (F) hose assembly to the 3/8 NPT thread in the (G) control handle assembly.
7. Attach the 1/4 NPT thread of the (N) bent pipe assembly to the outlet of the (G) control handle assembly.

CAUTION: DO NOT CONNECT THE AIR AT THIS TIME.

NOTE: Apply a thread sealer or PTFE tape to all pipe threads.

PUMP SERVICE PROCEDURES

PUMP DISASSEMBLY

To disassemble the lower pump assembly from the 65444-B air motor assembly:

1. Clamp the air motor assembly in a vise as shown in Figure 2.
2. Loosen the 90606 lock nut.
3. Place strap wrench around the 76048 spacer tube and remove by turning counter clockwise. If the strap wrench slips on the 76048 spacer tube, wrap a piece of 400 sand paper around the 76048 spacer tube and under the strap wrench. (NOTE: Pipe wrench will damage the finish of the tube).
4. After the 76048 spacer tube has been unscrewed from the 65444 air motor assembly, pull the lower pump assembly down until the (3) plunger is exposed.
5. Place a 1-3/16 open end wrench or an adjustable wrench on the flats of the (3) plunger and a 1-1/8 wrench on the 90609 retaining screw as shown in Figure 3.

CAUTION: Extreme caution should be used when disassembling the (3) plunger to prevent scoring the plunger. Do not use a pipe wrench or pliers on the plunger.

6. Set the lower pump end aside.
7. Remove the 76748 gasket from the 65444-B air motor assembly.

PUMP REASSEMBLY

1. Insert the 76748 gasket into the air motor base.
2. Clean threads, apply Loctite #242 to the threads of the 90609 retaining screw and screw them securely into the (3) plunger. See Figure 3.
3. Apply PTFE tape or Parker Ferulube to the threads on the (2) spacer tube and screw it into the 65775 air motor base and insert assembly.
4. Tighten the (1) lock nut.

SPECIAL TOOLS AVAILABLE

- 21946T used to install 76947 Packing Screw in 641529 and 641523 Control Handles.
- 90350 Inserting Tool. Allows a positive seating to guide Ring and Adapter in Air Motor.
- 640081-B Aro Strap Wrench.
- 38237 Spanner Wrench. Tightens Seat in Lower Wash Pump.
- 37437-1 Loctite 271 Liquid Lock.

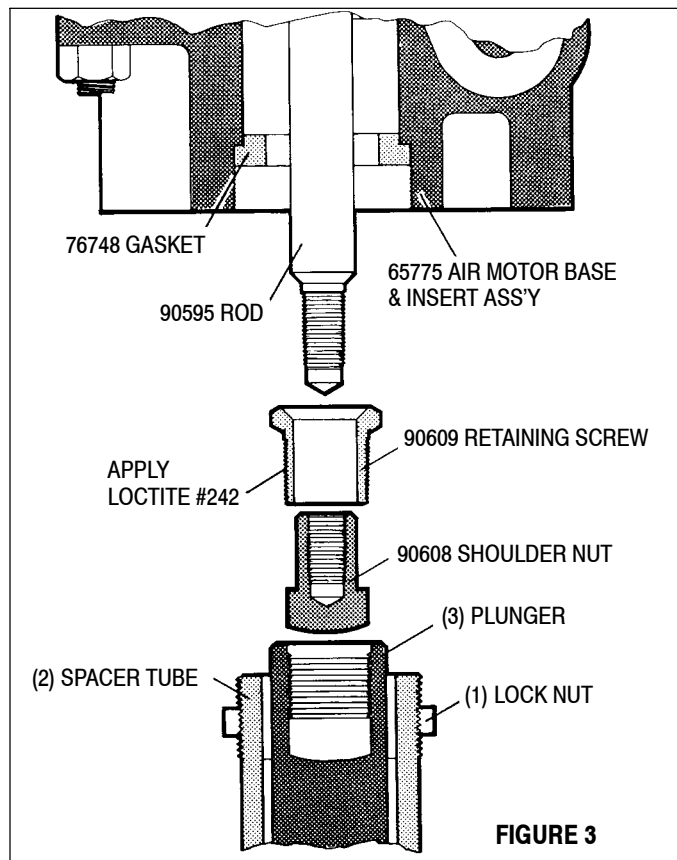
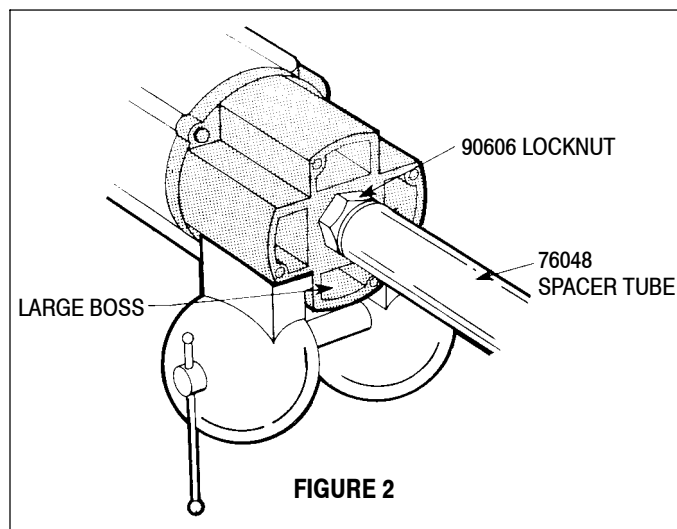

LOWER PUMP SERVICE PROCEDURES

LOWER PUMP DISASSEMBLY

NOTE: All threads are right hand.

1. Clamp the lower pump assembly in a vise side ways on the (7) pump body with the material outlet up.
2. With a plastic hammer tap all around the lower end of the (16) suction tube. (Close to the bottom).
3. Place strap wrench around the (16) suction tube and hold securely. Place a wrench on the foot valve body and disassemble from the suction tube.
4. Remove the (17) dowel pin and (20) ball from the (21) foot valve body.
5. Remove the (19) "O" ring from (21) foot valve body.
6. Disassemble the (16) suction tube from the pump body.
7. Remove the (3) plunger using extreme caution not to damage the finish on the O.D.
8. Remove the (9) "O" ring from the (7) pump body.
9. Place the strap wrench on the (2) spacer tube and unscrew the spacer tube from the (7) pump body.
10. Place a wooden dowel or hammer handle in the (2) spacer tube and lightly tap the (4) washer, and the (5) packing out of the chamber.
11. Remove the (6) gasket from the (7) pump body.
12. Clamp the flats of the (11) rod in the vise. Remove the (3) plunger and the (10) lock washer from the (11) rod.
13. Remove the (15) nut.
14. With a spanner wrench remove the (14) retaining nut.
15. Remove the (12) cup and (13) "O" ring.

LOWER PUMP END REASSEMBLY

NOTE: Use anti seizing compound on all stainless steel threads.

1. Thoroughly grease and install the (4) washer, and the (5) packing into the bore of the (2) spacer tube with the lips toward the opening.
2. Seat the (6) gasket in the (7) pump body.
3. Apply PTFE tape or Parker Ferulube to the threads on the end of the (2) spacer tube that the packing was installed into, and insert into the top of the (7) pump body (top does not have external threads) and screw securely together.
4. Thoroughly grease and install the (9) "O" ring into the bottom of the pump body.
5. Place the (3) plunger (with 1/2 - 20 thread down) into the top of the (2) spacer tube, and slowly work the plunger through the (5) packing, until the plunger extends out of the (7) pump body.
6. Place the (10) lock washer over the threads on the (11) rod.
7. Clean the threads of both pieces with solvent, apply Loctite and screw securely onto the (3) plunger.
8. Slide the assembled (12) cup and (13) "O" ring onto the (11) rod.
9. Thoroughly clean with solvent and apply Loctite to the 7/16 - 20 threads of the (11) rod.
10. Screw the (14) retaining nut onto the (11) rod and tighten with a spanner wrench.
11. Screw the (15) nut onto the (11) rod and tighten.
12. Push the assembled (3) plunger and (12) cup up until the cup comes in contact with the (7) pump body.
13. Thoroughly grease the inside of, and apply PTFE tape or Parker Ferulube to the external threads of the (16) suction tube. Carefully force the externally threaded end of the suction tube over the (13) "O" ring and screw into the (7) body.
14. Thoroughly grease and install the (19) "O" ring on the (21) foot valve body.
15. Place the (20) ball in the (21) foot valve body and insert the (17) dowel pin into the two holes in the foot valve body.
16. Apply PTFE tape or anti-seizing to the threads of the (21) foot valve body and screw them into the (16) suction tube and tighten securely.
17. The lower pump end is now assembled.

LOWER PUMP END PARTS LIST

ITEM	DESCRIPTION	Qty	Part No.
◇	SERVICE KIT PARTS		637001
1	Locknut	1	90606
2	Spacer Tube	1	76048
3	Plunger	1	90615
◇ 4	Washer	1	77398
◇ 5	Packing	1	77744
◇ 6	Gasket	1	76748
7	Pump Body	1	65793-2
8	Locknut	1	76248
◇ 9	"O" Ring (2.129" o.d.)	1	77361
10	Lockwasher (1/2")	1	Y14-816-T
11	Rod	1	76045
◇ 12	Cup	1	77265
◇ 13	"O" Ring (3/16" x 1-7/8" o.d.)	1	Y325-325
14	Retaining Nut	1	76046
15	Nut (7/16" - 20)	1	Y11-7-T
16	Suction Tube	1	90621
17	Dowel Pin	1	90620
◇ 19	"O" Ring (1/8" x 2" o.d.)	1	Y325-224
20	Ball	1	90948
21	Foot Valve	1	76932
22	Adapter (3/4 NPT x 3/8 NPT)	1	Y45-308-T

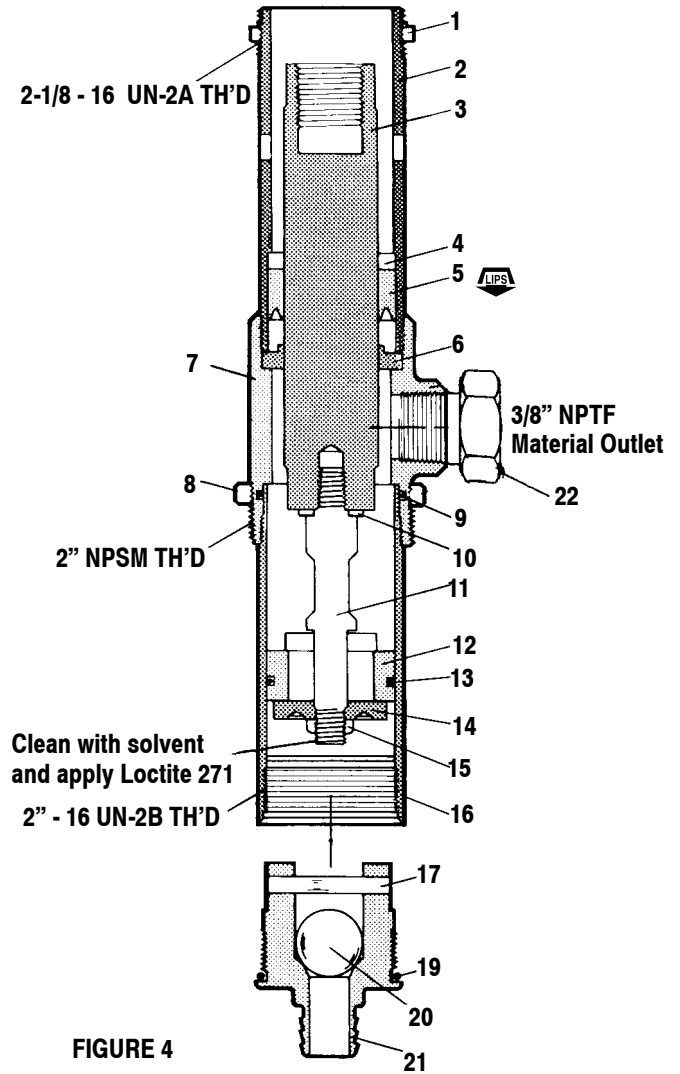

FIGURE 4

Use Loctite Nickel Anti-Seize on All Threads.
 Use Tricresyl Phosphate (Wet-Sol "Plus") only
 to Lubricate Packings when Assembling Pump.

TROUBLE SHOOTING

No material (stalled pump).

- Obstructed (R) spray tip. Remove spray tip and clean.
- Obstructed (F) hose assembly. Remove control handle and operate pump until line is clear.
- Obstructed (G) control handle assembly. Disassemble and clean.

No material (Pump continually cycles).

- Empty material supply. Disconnect the air. Replenish material supply. Connect the air. Open (G) control handle assembly until pump is primed.
- 90609 Retaining screw (See Figure 3) disassembled from (3) plunger. (Figure 4). Connect the retaining screw to the plunger. (Follow instructions for assembly of air motor to lower pump end).
- Damaged (H) lower suction tube. Replace suction tube.
- Loose (J) hose clamp assembly on (K) tube. Tighten clamp.

Material on One Stroke only (Fast Downstroke).

- (20) Ball in (21) foot valve not seating, or damaged (19) "O" Ring. Remove the foot valve. Remove the ball from the foot valve. Clean and inspect ball and foot valve. If either ball or foot valve is damaged, replace, also replace (19) "O" Ring if damaged. (See Lower Pump End Instructions).

Material on One Stroke only (Fast Upstroke).

- Worn (13) "O" Ring. Replace with new (13) "O" Ring. (See Lower Pump End Instructions).

Material Leakage Out the Oil Daily Holes in Pump.

- Worn (5) packing. Replace worn packing. (See Lower Pump End Instructions).

Air leakage out of the Main Exhaust.

- Worn 90796 valve insert. Replace the valve insert. (See Air Motor Instructions).
- Loose 65027 Piston Assembly. Tighten piston assembly. (See Air Motor Instructions).
- Damaged 65027 Piston Assembly. Replace piston assembly. (See Air Motor Instructions).
- Warped or worn 65028 valve plate and pin assembly. Replace valve plate and pin assembly.

Continual leakage out of the bleeder hole in the Head Assembly.

- Worn 91207 "O" Ring or 91007 Seal. Replace the "O" Ring and Seal. (See Air Motor Instructions).

Air leakage out of the bleeder hole on the Air Motor Assembly downstroke.

- Worn Y186-51 "U" cup. Replace the "U" cup. (See Air Motor Disassembly Instructions).

Air leakage out of the Oil Daily Holes in the Pump Section.

- Worn Y325-210 "O" Ring. Replace the "O" Ring. (See Air Motor Instructions).

Material leakage around the Control Handle.

- Loose 76947 gland. Tighten packing screw. (See Control Handle Instructions).
- Worn 77516 packings. Replace packings. (See Control Handle Instructions).

OPTIONAL ACCESSORIES

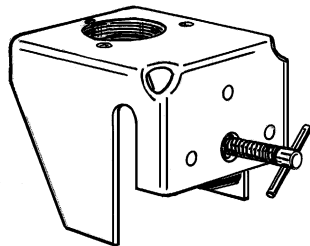

61113 MOUNTING BRACKET

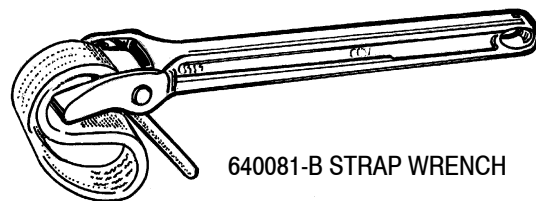

640081-B STRAP WRENCH

FIGURE 5